



MPU 600

Datenblatt

Fahrbare Hochleistungspumpe

Grundausrüstung

- ▣ Prüfmedium: Wasser über ext. Versorgung bis 600 bar
Hochdruck Gas- und Luftprüfung über ext. Versorgung bis 300 bar
- ▣ Drucksystem: PN600 bar Edelstahl
- ▣ mobile Einheit in Edelstahlgehäuse
- ▣ 5m Hochdruckschlauch
- ▣ Eloxierte, chemikalienresistente Fronttafeln
- ▣ Manometerschnellverschraubung für werkzeugfreien Manometerwechsel
- ▣ METRUS Präzisionsventiltechnik

Specifications

Mobile pressure unit

Basic features

- ▣ Test fluid: Water via ext. supply up to 600 bar
Highpressure air and gas via ext. supply up to 300 bar
- ▣ Pressure piping: PN600 bar stainless steel
- ▣ mobile unit in stainless steel housing
- ▣ 5m Highpressure hose
- ▣ Anodized, chemical resistant front panel
- ▣ Gauge quick connection for tool free change of gauges
- ▣ METRUS Precision valves



Optionen

- ☐ Höhere Druckstufen bis 1600 bar
- ☐ Externer Wassertank mit pneumatischer Füllpumpe
- ☐ METRUS Free CRS - kostenlose Prüfstandssoftware

Options

- ☐ Higher pressures up to 1600 bar
- ☐ External water tank with air driven filling pump
- ☐ METRUS Free CRS - free of charge computer registration system

Abmessungen Vorder- u. Rückansicht

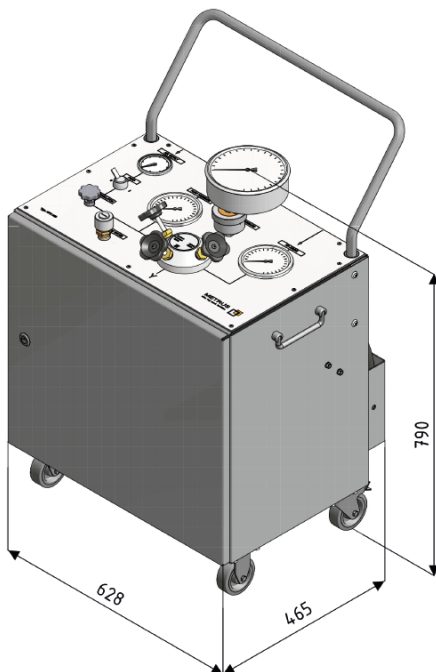

Dimensions back- and front-side view

